

(No Model.)

2 Sheets—Sheet 1.

M. P. MÖLLER.

PIPE ORGAN.

No. 343,049.

Patented June 1, 1886.

Fig. 1.

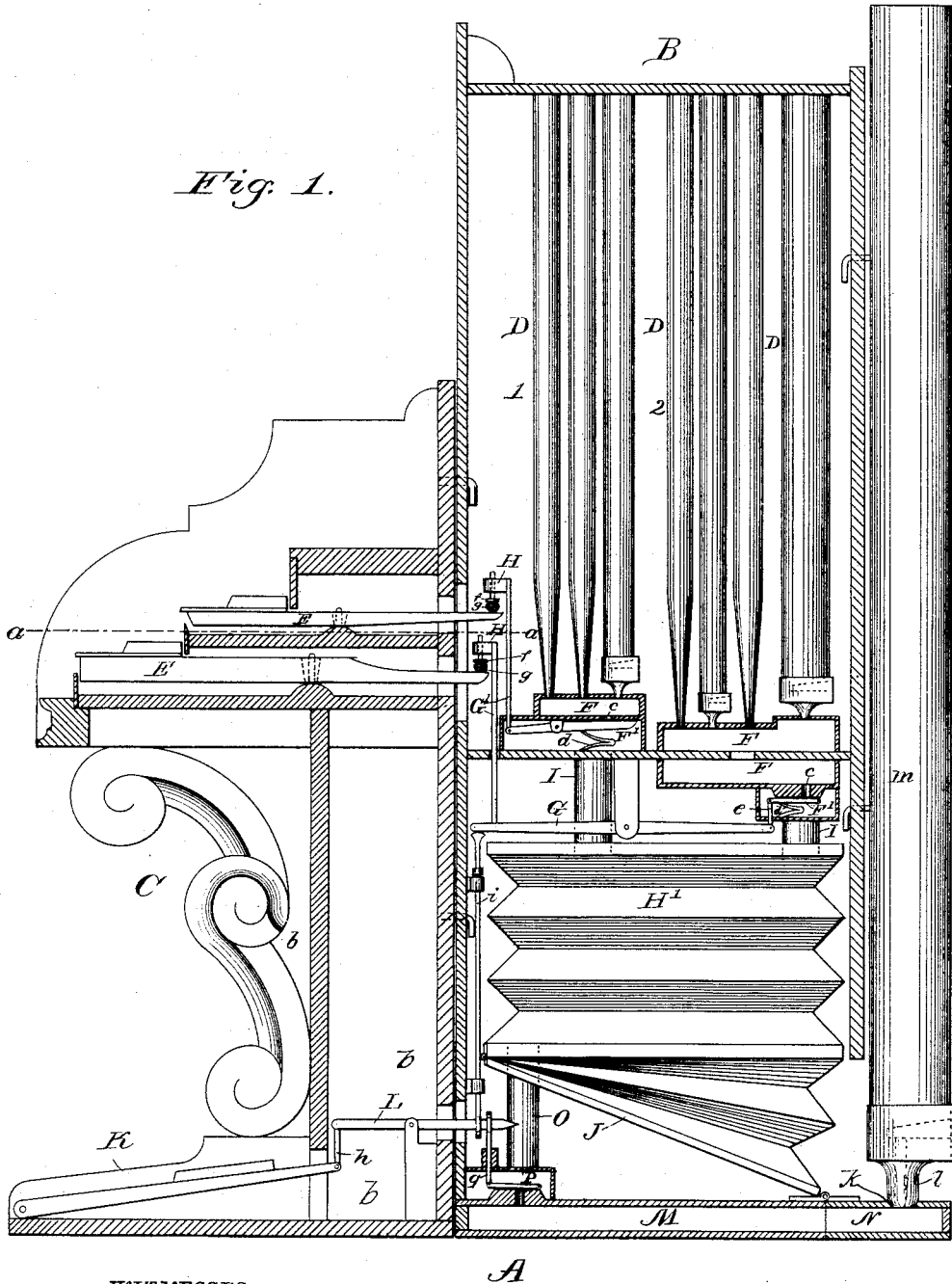

WITNESSES

*Roy C. Bowen.*  
*Wm. H. Moore.*

A

INVENTOR

*Matthias P. Möller.*

By *C. A. Snow & Co.*

*Leis. Attorneys.*

M. P. MÖLLER.

PIPE ORGAN.

No. 343,049.

Patented June 1, 1886.

Fig. 2.

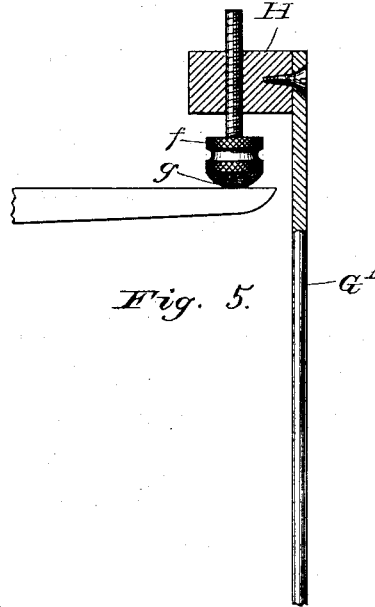
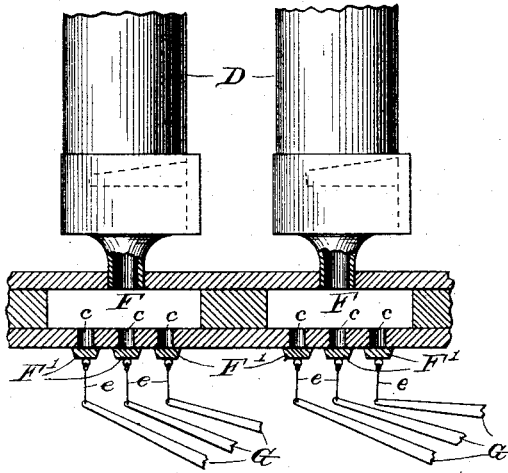

Fig. 5.

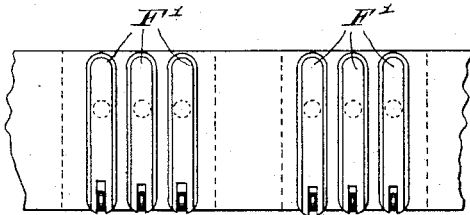

Fig. 3.

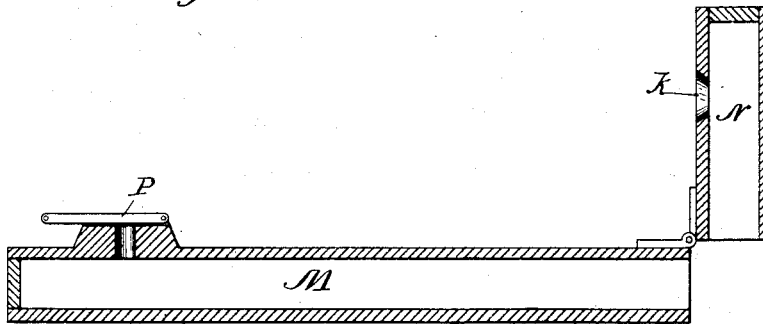

Fig. 4.

WITNESSES

*Ray G. Bowen.*  
*John M. Moore.*

INVENTOR

*Mathias P. Moller.*

By *C. A. Snow & Co.*  
 His Attorneys.

# UNITED STATES PATENT OFFICE.

MATHIAS P. MÖLLER, OF HAGERSTOWN, MARYLAND.

## PIPE-ORGAN.

SPECIFICATION forming part of Letters Patent No. 343,049, dated June 1, 1886.

Application filed July 3, 1885. Serial No. 170,627. (No model.)

*To all whom it may concern:*

Be it known that I, MATHIAS P. MÖLLER, a citizen of the United States, residing at Hagerstown, in the county of Washington and State of Maryland, have invented a new and useful Improvement in Pipe-Organs, of which the following is a specification, reference being had to the accompanying drawings.

My invention relates to organs, and particularly to that class known as "pipe-organs," the object being to construct the same of two sections, one carrying a bank or banks of keys and the other section the organ-action, whereby the organ may occupy but a minimum amount of space for transportation, and may be readily carried through a door of ordinary size without taking the organ to pieces, as has heretofore been necessary.

A further object of the invention is to provide a pipe-organ with a series of detachable pipes, and with a hinged support for the same, which support is adapted to be folded to economize space in transportation.

A further object of the invention is to provide improved means for leveling the keys when any one of the same drop below the others of the bank.

With these ends in view the invention consists in the improved construction and combination of parts hereinafter fully described, and pointed out in the claims.

In the drawings, Figure 1 is an end elevation of an organ embodying my invention with the end removed. Fig. 2 is an end elevation of two of the wind-pipes. Fig. 3 is a bottom view of the same, showing the arrangement of valves. Fig. 4 is a detail view showing the hinged portion of the pedal air-passage thrown up. Fig. 5 is a detail view of means employed for leveling the keys.

In the accompanying drawings, in which like letters of reference indicate corresponding parts in all the figures, A represents the organ, which is constructed of two sections, B and C, the section B having within it the organ-action and the section C carrying the key board or boards and the pedals. As a means of attaching the section C to section B, I have shown said section C provided with L-shaped hooks projecting from the rear side thereof, which hooks are adapted to engage openings in the section B. I have shown this form of attach-

ing means as the means preferably employed; but it will be readily seen that there are numerous ways in which the said sections might be detachably secured together; hence I do not wish to limit myself to the construction shown.

In the event that but one bank of keys is employed, the key-board would be of about the size shown below the dotted line *a a*, exclusive of the ornamental moldings shown at *b*. In this case the board would be hinged or otherwise attached to section B at its upper end, so that it could be turned up against the same, thereby obviating the necessity of detaching the parts.

E represents the keys, which are so mounted midway their ends that they may have a rocking motion, as usual, the inner ends of the keys extending into the section B.

D represents the pipes, which are arranged in series of threes, as shown, and at the lower ends of these pipes are provided air-chambers F, having in their bottoms openings *c*. If one bank of keys is employed, there will be two openings, and if two banks of keys are employed three openings, the other opening being controlled by a valve operated by the pedal.

F' represents the valves, which are arranged under the air-chambers F and are so supported midway their ends that when their front ends are raised their rear ends will be lowered from the openings, and thus allow the passage of air to the pipes. Arranged beneath the valves F' are flat springs *d*, which are adapted to hold the valves in place over the openings *c*, and prevent their accidental dropping or displacement therefrom. In the series of pipes No. 1 the valves are connected directly to rods, which are operated upon by the keys by raising said rods, and thus lowering the valves from engagement with the openings; but in the series No. 2 the valves F' are connected at their front ends with levers G, pivoted centrally by means of wires *e*.

G' represents the rods for operating the valves. In the series No. 1 these rods are connected directly to the valves F', while in series No. 2 they are connected to the front ends of levers G. Upon the upper ends of these rods are provided forwardly-extending blocks H, provided with vertical passages or openings, in which are located thumb-screws

*f*, upon the lower ends of which are secured leather washers *g*, having a covering of felt or similar material to deaden the sound. It will be seen that by lowering the set-screws the front ends of the keys may be raised, so that should one of the keys drop below the level of the rest of the bank it may be raised by lowering the set-screws upon the inner or rear end of the key.

It will be observed that in the series of pipes numbered 1 that the flat springs for holding the valves in position may be dispensed with, from the fact that the rods *G'* bear upon the outer ends of the valves, and thus hold their inner or rear ends in place.

Arranged below the pipes and their valves is an air-reservoir, *H'*, from which lead pipes *I* for supplying air to the chambers arranged below each series of pipes, and for supplying air to said reservoir is a bellows, *J*, arranged beneath the reservoir, as shown.

*K* represents the pedal, hinged or pivoted at its front end.

*L* represents a rod or shaft journaled in the moldings *b* and connected with the inner end of the pedal by a short arm, *h*. The inner end of this rod *L* is connected with one of the levers *G* by a rod, *i*, so that when the inner end of the pedal is lowered it will lower the lever, which will overcome the spring and remove the valve from the opening and supply air to the pipe.

Upon the under side of the organ is provided an air-passage or channel, *M*, at the rear end of which is a hinged section, *N*, extending beyond the rear-end of the organ, which section is closed at its outer end, and is provided on its upper side with a seat or recess, *k*, in which rests the foot *l* of one of the pedal-pipes *m*. These pedal-pipes *m* are detachable from the section *B* of the organ, and are preferably attached thereto by hooks, as shown.

*O* represents an air-passage leading from the air-reservoir to the passage leading to the pedal-pipes. An opening is made in the passage leading to the pedal-pipes, and closing the same is a valve, *P*, attached to the free end of which is a rod, *q*, which connects with a pivoted arm connected with the pedal, which arm is constructed and arranged similar to those described for operating the valves of the series of pipes 1.

By the construction before described a pipe-organ is provided which possesses great power and variety of tone, the detachable parts described may be readily and easily separated from the body or main section of the organ, and readily attached thereto, the services of an organ-builder or mechanic not being necessary for this purpose, as is the case with organs as now constructed, wherein it is necessary to separate the same for transportation and to allow it to be carried within a building.

I am aware that organs have been made in detachable sections for portability, and the same is therefore not broadly claimed.

Having thus described my invention, I claim—

1. A portable organ made in sections detachably coupled together, comprising a body having the organ-action, a section carrying a pedal and bank or banks of keys, the air-passage, and the pedal-pipes located without the body and in communication with the air-chamber, substantially as described.

2. A portable organ made in separable sections adapted to be coupled for operation and comprising a body having the organ-action, a section carrying the pedal and bank or banks of keys, the air-passage having the valve-chamber, and a flexible connected section extending beyond the body, and a pedal-pipe fitted on a seat and in communication with the air-passage, substantially as described.

3. The combination, with an organ, of detachable pedal-pipes located without the same, as set forth.

4. The combination, with an organ having the air-passage, of the hinged section supporting a detachable pedal-pipe, as set forth.

5. The combination, with an organ having the air-passage having the hinged section extending beyond the rear end of the same, of the pedal-pipe resting on and communicating with the air-passage and detachably secured to the body of the organ, as set forth.

6. The combination, with a key and its valve-connecting rod, of a bearing-block secured to the rod, a vertically-adjustable shaft mounted in the block and having a thumb-screw, and an elastic washer rigidly secured on the thumb-screw and bearing against the rear ends of the key to level the same, substantially as described.

7. The combination of the organ-body, the exterior pedal-pipe, and air-passage, on which the pipes are seated and having the valve-chamber at one end in communication therewith, a valve, the pedal, a pivoted lever connected to the pedal, and a link connected with the pedal and valve, substantially as described.

8. As a device for leveling the keys of an organ or the like, a block carrying a thumb-screw adapted to bear on the rear ends of the keys, an elastic washer or disk on the end of the thumb-screw, and a felt or like covering for the washer, as set forth.

In testimony that I claim the foregoing as my own I have hereto affixed my signature in presence of two witnesses.

MATHIAS P. MÖLLER.

Witnesses:

GEO. T. LEITER,  
ALEX. ARMSTRONG.